

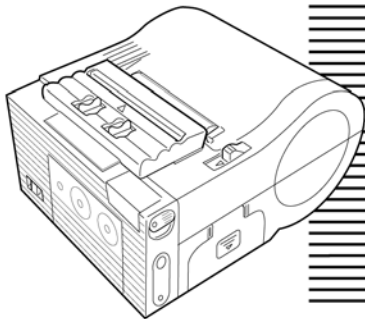

Barcode Printer  
**MB200**

Operator's Manual



## **Introduction**

---

Thank you for your purchase of the SATO barcode printer MB200.

This manual helps first time users understand the basics of the printer in a short period of time.

To get the most out of the functions of the printer, make sure to read this manual carefully.

## **Warning!**

---

1. This manual may not be reproduced whole or in part without prior consent from SATO.
2. The information in this manual is subject to change without notice.
3. Despite this manual has been created to be as accurate as possible, contact the shop or the dealer where you purchased this product if you find any errors or mistakes.

## **Caution**

This printer is a Class A Information Technology Equipment based on VCCI standards. There may be a risk of interference when used at home, in which case the user may need to take necessary countermeasures.

## Features of MB200

---

With compact and lightweight body combined with high performances, this printer prints barcodes clearly on various types of thermal paper.

- **Excellent Printing Performance**  
Not only does this printer print barcodes clearly, but it can also enlarge and print various types of fonts and Kanji characters in a free layout.
- **Durable and Easy to Use**  
This printer is also superb in durability, as it has been designed with the premises of printing barcodes. Also, special consideration has been taken so that the printer can be easily cleaned everyday.
- **Dispenser Function**  
As a portable printer, this printer can easily print and dispense labels to enable the application of labels at site.

## Table of Contents

Preparation	1. Safety Precautions .....	5
	Markings and Symbols.....	5
	Precautions in Use .....	13
	2. Unpacking .....	14
	3. Part Names .....	15
	Name and Function of Operating Parts .....	17
	4. Before Starting .....	18
	Charging the Battery Pack.....	18
	Installing and removing the Battery Pack.....	20
	Using the AC Adapter .....	22
Operation	Setting Labels .....	23
	Continuous Mode.....	23
	Dispense Mode .....	25
	Changing Roll Width .....	26
	5. Turning the Power on and off .....	27
Trouble Shooting	6. Starting the Printer .....	28
	Procedures for On-line Operation .....	29
	On-line Operation.....	31
Maintenance	Test Printing Mode .....	37
	7. Trouble Shooting.....	38
Reference	8. Everyday Maintenance.....	40
	9. Reference.....	41
	Options.....	41
	Ordering Repairs.....	45
	Basic Specifications .....	46
	After service .....	48

# 1. Safety Precautions

In this section, safety precautions about printer operation are explained to ensure proper care and usage. Make sure to read these carefully before using your printer.

1

Safety Precautions

## Markings and Symbols

---

The following symbols or markings are used in this User's Guide and on the printer so that you can properly use the printer, and to prevent any damage to property, harm or injury to yourself and others. Make sure to read their explanations carefully to familiarize yourself with their meanings.



**Warning**

This symbol indicates information that, if ignored or applied incorrectly, creates the danger of death or serious personal injury.



**Caution**

This symbol indicates information that, if ignored or applied incorrectly, creates the possibility of personal injury or property damage.

## Symbol example



The triangle () indicates something you should take absolute care when doing. The cautions are indicated concretely within the symbol. The symbol on the left indicates caution with electric shock.



A diagonal line within a circle () indicates something you should not do. The symbol on the left indicates you should not try to take the unit apart.



A black circle () indicates something you need to do. The symbol on the left indicates you should unplug the unit from the wall outlet.



## Warning!

### Liquids



Do not place any containers with water or chemicals, such as flower vases or cups, as well as small metallic objects near the printer. If any of these should fall into the printer, immediately turn off the power and contact your nearest dealer or service center. Continued use creates the danger of fire or electrical shock.

### Foreign Matter



Do not drop or insert metallic or flammable objects into the openings on the printer (such as outlets for cables). If any of these should fall into the printer, immediately turn off the power and contact your nearest dealer or service center. Continued use creates the danger of fire or electrical shock.

### Dropping and Damage



Should the printer ever fall or otherwise become damaged, immediately turn off the power and contact your nearest dealer or service center. Continued use creates the danger of fire or electrical shock.



## Warning!

1

Safety Precautions

### Abnormal Conditions



Continued use of the printer while it is emitting smoke or strange odor, creates the danger of fire or electrical shock. Immediately turn off the power and contact your nearest dealer or service center for repairs. Do not try to service the printer by yourself.



### Disassembly



Never try to take the unit apart or modify it in any way. Doing so creates the danger of fire or electrical shock. Contact your nearest dealer or service center for checkups, tuning and repairs.



### Battery Pack



- Never try to take apart the battery pack or modify it in any way such as with a solder.
- Never expose the battery to direct flame, throw it into fire, or take any actions that may lead to shorting.
- When charging the battery pack, make sure to use the specified battery charger.







## Warning!

### AC Adapter / Battery Charger (Optional)



- Use only the specified voltage. Using a different voltage may create the danger of fire or electrical shock.
- Never use the battery charger with any other battery pack except for the specified one. Doing so can rupture the battery, cause leakage, fire or electrical shock.
- Never cut, damage or modify the power cord. Also, never place heavy objects on, set fire to or pull the power cord, as it can damage the cord and create the danger of fire or electrical shock.
- Should the power cord ever become seriously damaged (internal wiring exposed or shorted), contact your nearest dealer or service center. Continued use of such a cord creates the danger of fire or electrical shock.
- Never modify, excessively bend, twist, or pull the power cord. Doing so creates the danger of fire or electrical shock.

**Caution!****Location**

Do not locate the printer in areas subjected to high humidity or dew. If dew forms inside the printer, immediately turn off the power and do not use it until it has dried up. Continued use creates the danger of electrical shock.

**Power**

Never operate the power switch, replace the battery pack or unplug the AC adapter or battery charger with wet hands. Doing so creates the danger of electrical shock.



**Caution!**

### **Thermal Head and Stepping Motor**



- The thermal head gets very hot after printing. Take care when replacing labels after printed and when cleaning to avoid burn.
- Touching the edge of the thermal head with bare hands may cause injury. Take care when replacing labels or cleaning to avoid injury.
- Do not try to replace the thermal head by yourself. Doing so creates the danger of injury, burns or electric shock.

---

### **Easy Cutter**



This part contains a blade. Take care to avoid cutting your hands.



**Caution!**

**1**

Safety Precautions

## Replacing the Battery Pack



- Use only the specified battery pack.
- When replacing the battery pack, make sure to install the pack with the poles (+) and (–) facing the correct direction. Incorrectly replacing the battery can rupture the battery and create the danger of injury or damage to surrounding areas due to leakage.
- When disposing of old battery packs, make sure to contact your nearest dealer or service center.

---

## Not using the printer for a long time



- Remove the battery pack from the printer and unplug the AC adapter from the wall outlet if you do not plan to use the printer for a long time.

---

## Maintenance and Cleaning



- For safety during maintenance and cleaning, make sure to remove the battery pack and the AC adapter from the printer.

## Precautions in Use

---

Do not place the printer in hot or cold places.  
The operation temperature range is within 5°C to 40°C. Do not place it in areas with high humidity or temperature out of the operation range.

Do not drop the printer or subject it to impact or vibrations.  
The printer can handle normal vibrations when being transported. However, care should be taken so that the printer is not subjected to strong vibration or impact of falling down.

Never disassemble or modify the printer.  
Do not open the printer by yourself as the components inside the printer are of high precision and have been finely adjusted.

Use only the specified cable to connect to the external input terminal.  
When connecting external equipment via the external input terminal, make sure to use the specified cable for connection. If you have any questions, consult with your nearest dealer or service center.

Make sure to use the specified optional equipment.  
Using other equipment besides the ones specified may create damage.

Make sure to use the specified labels.  
Using other types of labels besides the ones specified may cause the print head failure or faulty printing.

## 2. Unpacking

2

Unpacking

After opening the box, make sure that all the printer's accessories are included. If there are any accessories missing, contact your nearest dealer or service center.

Guarantee  
Certificate

User's Guide

Printer

Battery pack

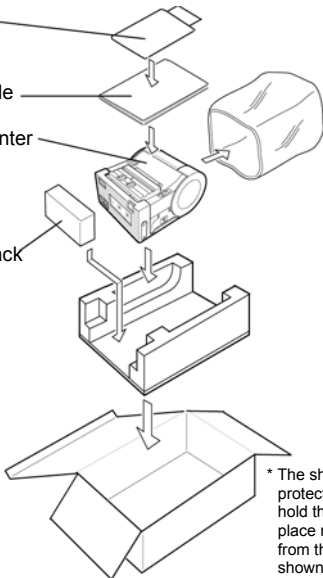

\* The shape of the protector pads to hold the printer in place may differ from the picture shown.

### 3. Part Names

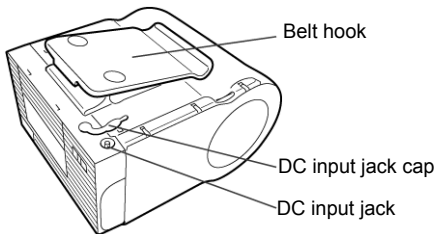
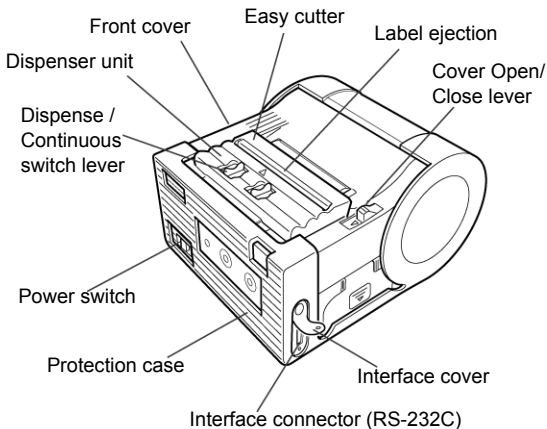

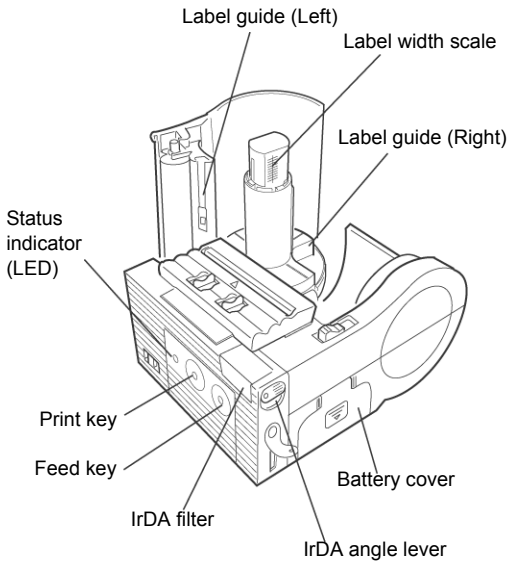

\* See “Reference” on page 41 for other optional parts.



## Name and Function of Operating Parts

---

Interface connector (RS-232C):

For the connection to a computer.

Interface cover:

Covers the interface connector.

Front cover:

Open this for setting labels.

Cover Open/Close lever:

Opens and closes the front cover.

Easy cutter:

Cuts printed labels.

IrDA adjustment lever:

Changes the angle of the IrDA receiving element.

IrDA filter:

The IrDA receiving element is located inside.

Dispenser unit:

Move this when using the Dispense mode.

Power switch:

Press to turn the power on and off.

Battery cover:

The battery pack is inserted here.

Belt hook:

Attaches the shoulder belt when hanging the printer on the belt.

\* Do not hang the printer on to anything else but the belt.

Label guide:

Adjust this to the label size being used.

Label ejection:

The printed label comes out from here.

Label width scale:

Scale for measuring the width of the label being used.

DC input jack:

For connection of the AC adapter.

DC input jack cap:

Covers the DC input jack.

Feed key:

Press to feed labels

Print key:

Press to set the printer to online or off-line.

STATUS indicator (LED)

Indicates the status of the printer. (Refer to page 29, 30, 38 and 39)

# 4. Before Starting

## 4 Charging the Battery Pack

Before Starting

Place the battery pack on the battery charger (optional) to charge it.

- (1) Plug one end of the power cord into the battery charger and the other end into the wall outlet.

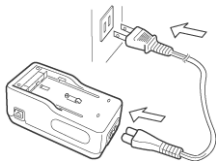

- (2) Place the battery pack on the battery charger and slide it in the direction of the arrow. When the battery pack starts charging, the CHARGE indicator lights up in orange. When the battery pack is fully charged, the indicator turns off. (Fully charged).

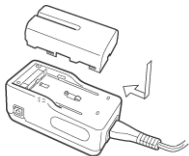

- (3) Remove the battery pack from the charger after it has finished charging. Slide the battery pack from the charger in the opposite direction to when placed on the charger.



## Notice

- If the indicator on the charger does not light up, make sure that the battery pack is firmly attached to the charger. The battery may not charge, if not firmly attached.
- When an already charged battery pack has been attached on the charger, the indicator on the charger turns on once and then off.
- If charging a battery pack that has not been used for a long period, the indicator on the charger may flash for a while. This does not indicate an error, and you can continue charging as it is.
- The battery pack can be charged up to 300 times (during use in regular temperatures). If the battery pack is fully charged but soon runs out, replace the battery pack with a new one.

### Charging Time

The duration of the battery pack from empty until fully charged is about 2.5 hours.

### Battery pack charge confirmation mark

When the battery pack is removed from the printer, the charge confirmation mark on the back of the battery pack is blank.

When attaching the battery pack on the charger once and then removing it, a green black box (■) appears on the back of the pack.

By looking at the confirmation mark, you can check if the battery is charged or not.

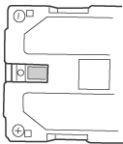

## Installing and removing the Battery Pack

### 4

#### Before Starting

\* Remove the Protection case.

- (1) Place your finger on the battery cover ribbed area, and slide it as far as it will move in the direction of the arrow.

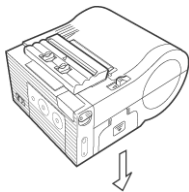

- (2) After releasing the battery cover lock, open the battery cover in the direction of the arrow.

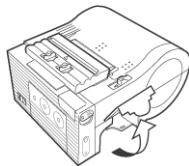

- (3) Insert the battery pack. After that, take the above procedure in reverse order to close the battery cover.

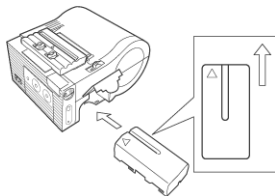

- (4) When removing the battery, place your finger into the notch on the battery and pull the battery out.

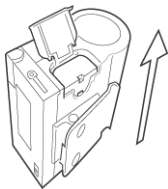

- \* Make sure to turn the power off before removing or replacing the battery.  
When the power is turned off, the status indicator lights up in green. Do not remove the battery while the indicator lights up. After making sure that the status indicator is off, you may then remove the battery.
- \* If, after turning the power off, you remove the battery pack while the status indicator is lit in green, the information stored in the printer may not be refreshed.

## Using the AC Adapter

---

### 4

Before Starting

Plug the specified AC Adapter (optional) into the printer.

- (1) Take off the DC input jack cap, and plug the AC adapter into the DC input jack.

- (2) Plug the AC adapter into the outlet.

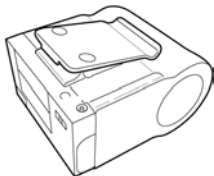

- \* Always turn off the printer when unplugging the AC adapter or DC output jack, or when cutting off the power source. When turning off the printer, the status indicator lights up in green. Do not cut off the power source while the light is on. Always make sure the green light is off when cutting off the power source.
- \* When the power source is cut off while the green light is on, the data in the printer memory may not be refreshed.

## Setting Labels

The method of setting the labels may vary depending on the print mode.

### Continuous Mode

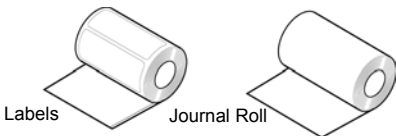

\* Remove the Protection case.

- (1) Place your fingers on the open cover ribbed area, and slide the cover Open/Close lever in the direction of the arrow.

\* Slide the Open/Close lever until the ▼ mark on the lever is covered.

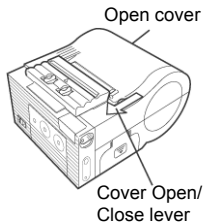

- (2) When the open cover pops open, fully open the cover in the direction of the arrow.



- (3) Place the label roll on the spindle on the open cover side.
- \* When inserting the label roll, make sure to press down the label core to prevent the labels from raveling out.
  - \* When removing remaining labels, insert your finger in the label core and remove the label with the core to prevent the labels from raveling out.

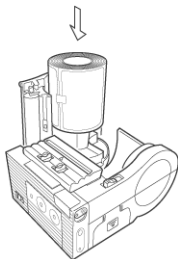

- (4) After peeling the leading tape on the roll, take the leading edge of the first label of the roll and pull it out from the label ejection via the platen roller. Then, adjust the label guide (left) to the label size, and pass the label underneath the label guides.

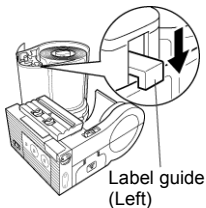

- (5) Place your fingers on the open cover ribbed area and close the open cover.

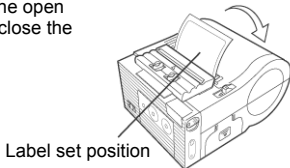

This completes the setting of labels when using the Continuous mode.



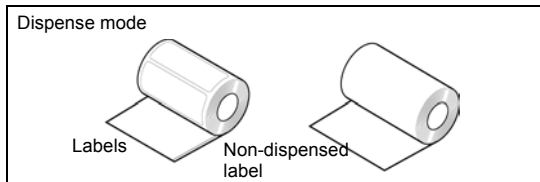

First perform steps 1 through 5 on pages 23 and 24 (Continuous mode)

- (1) Pick the Dispense/Continuous switch lever from both sides, and slide the Dispense unit to the direction of the arrow.
  - \* Leave more than 30mm of the label out for the Dispense mode.
  - \* Slide the Dispenser unit until it is set in place.
  - \* Always set the Dispenser unit back to the Continuous mode when opening/closing the cover.

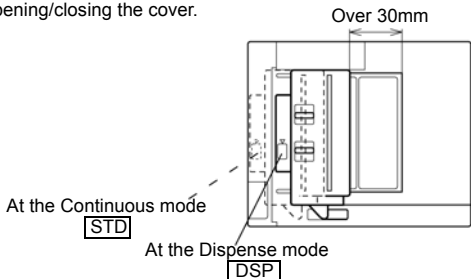
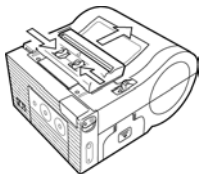

## Changing Roll Width

4

Before Starting

- (1) Check the width of the roll. Set the label guide scale to the width of the label, and slide until it overlaps.

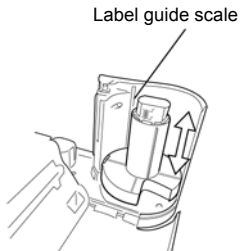

- (2) Roll the label guide clockwise and secure it in position. When rolling, hold the place on the label guide indicated in the illustration nearby.



- \* Perform steps 1 and 2 when changing rolls.

## 5. Turning the Power on and off

After preparations, turn on the power.

- (1) Slide the power switch to ON, and the status indicator lights up in green.

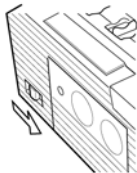

- (2) Slide the power switch to OFF and the status indicator goes off.

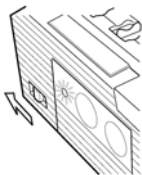

## 6. Starting the Printer

### 6

There are 2 modes for printing: the Continuous mode and the Dispense mode. Test printing and On-line printing can be done on both modes.

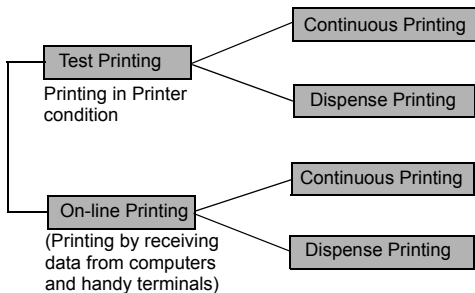

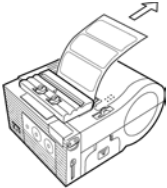
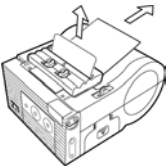
Continuous Printing	Dispense Printing
	

# Procedures for Online Operation

## Normal Printing Mode

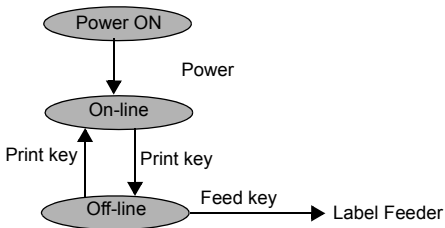

The status indicator during the Normal Printing mode is as shown on the table below

Action	Status (LED)
Normal Printing Mode	On (Green)
On-line	On (Green)
Off-line	Off

## Test Printing Mode (Feed key + Power ON)

### 6

#### Starting the Printer

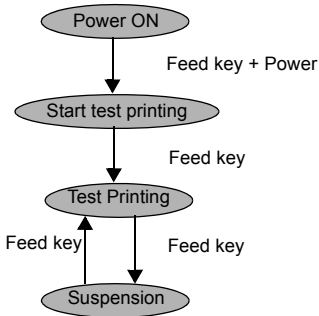

The status indicator during the Test Printing mode is as shown on the table below

Action	Status (LED)
Starting Test Print Mode	ON (Orange)
Test Print Mode	Blinking (Green)
Test Print Mode (printing)	On (Green)
Suspension	Off

## On-line Operation

Before starting on-line operations, follow the directions below.

### Put on the interface protector (optional)

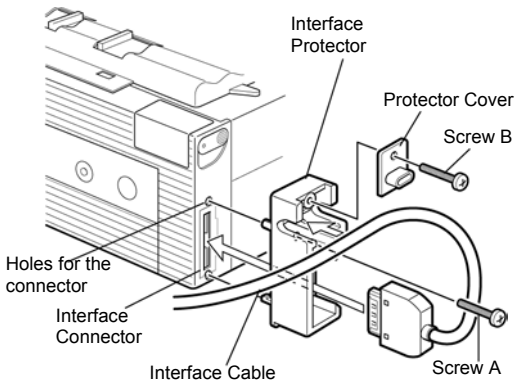

\* When using the interface cable, use the specified cables and interface protector.

1. Take off the interface connector cover.
2. Peel off the seal of the tape on the interface protector, and secure on to the two holes for the interface connector.
3. Plug the interface cable into the connector.

4. Set the interface cable.
  5. Tighten screw A.
  6. Fit the protector cover as indicated.
- \* When the cable is thin, place the jut the other way around.
7. Tighten screw B.
- \* Be sure to secure the interface cable from touching the battery cover when opening it.

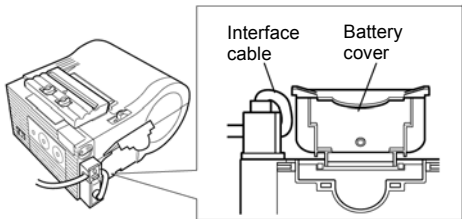

#### Setting up the DIP switch

- \* The DIP switch is visible when opening the cover.

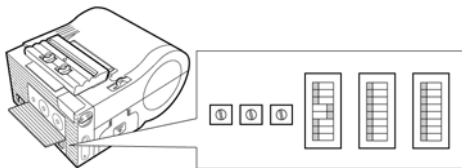



## Settings for the DIP Switch

### DIP Switch (DSW1)

Switch No.	Function				Initial Factory Default Setting
1-1	Interface Setup				DSW1-1
1-2	1-1	1-2	1-3	Action Mode	OFF
	OFF	OFF	OFF	RS-232C	DSW1-2
1-3	ON	OFF	OFF	TTL	OFF
	OFF	ON	OFF	IrDA transmission	DSW1-3
	ON	ON	OFF	Weak radio transmission (optional)	OFF
	OFF	OFF	ON	RS-232C, IrDA transmission	
	ON	OFF	ON	TTL, IrDA transmission	
	OFF	ON	ON	RS-232C, Weak radio transmission (optional)	
	ON	ON	ON	TTL, Weak radio transmission (optional)	
1-4	Unavailable for use				DSW1-4 ON
1-5	Head Check OFF : Head check is not in effect. ON : Head check is in effect.				DSW1-5 ON
1-6	Unavailable for use				DSW1-6 OFF
1-7					DSW1-7 OFF
1-8					DSW1-8 OFF

- Make sure the power is turned off before setting up the DIP switch.
- \* Unless directed otherwise, do not change the setup.

**DIP Switch 2 (DSW2)**

Switch No.	Function	Initial Factory Default Setting
2-1	Use when specifying printer ID number. * Unless directed otherwise, do not change the setup. * Command specification is available for printer ID number.	DSW2-1 OFF
2-2		DSW2-2 OFF
2-3		DSW2-3 OFF
2-4		DSW2-4 OFF
2-5		DSW2-5 OFF
2-6		DSW2-6 OFF
2-7		DSW2-7 OFF
2-8	Unavailable for use	DSW2-8 OFF

- Make sure the power is turned off before setting up the DIP Switch.

**DIP Switch 3 (DSW3)**

Unavailable for use

- Make sure the power is turned off before setting up the DIP Switch.
- \* Unless directed otherwise, do not change the setup.

## IrDA Adjustment Lever

By adjusting the angle of the lever, the angle of the IrDA receiving element can be changed.

(1) Use the rib of the lever to adjust the setting.

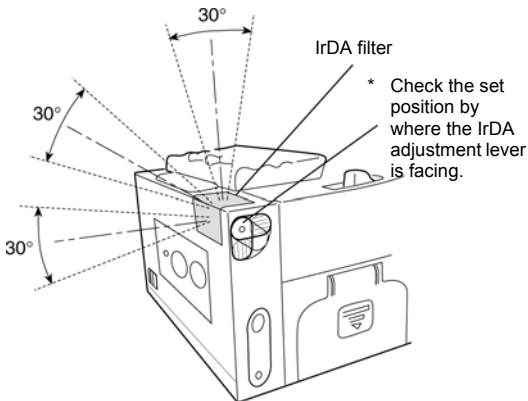

- The IrDA allowable distance is 15 to 20 cms at the maximum.
- \* Varies from the environment where printer is used. Under direct sunlight or strong lighting, it may not be possible to make IrDA transmittal. Should this happen, cover the IrDA filter to interrupt the light, or bring the IrDA filters to contact together.

## Test Printing Mode

---

- (1) Press the power switch to ON while pressing the Feed key to turn to the Test mode. To start test printing, press the Feed key again.

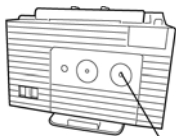

Feed key

- (2) Check the following after the test printing:
- \* Is the thermal head off or in place ?
  - \* Is the printing in good condition ?  
During test printing, the full battery is indicated as ■■■.  
When the indicator shows ■□□, recharge the battery.

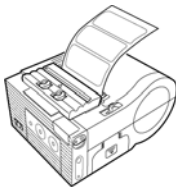

- \* Contact your nearest dealer or Customer Service Center for any problems. For repairs , see “Ordering Repairs” and follow the instructions.

# 7. Trouble Shooting

## 7

### Trouble Shooting

The status of the printer is indicated on the status indicator. Abnormalities of the status is indicated as below. To solve the problems, follow the directions in the table.

Status (LED)	Mode	Details	
Orange	All modes	Low battery	→
Red / orange (blinking)	On-line	Buffer over	→
Red	After turning on the power	1. Program error 2. FLASH ROM error	→
Orange (blinking)	On-line	Head error	→
Red (blinking)	On-line	Open cover	→
		Paper end	→
		Sensor error	→
Green (blinking)	On-line (printing / receiving data)	Buffer near full	→
Green/ Orange (blinking)	On-line	Head overheating protection function	→

The power will automatically be turned off 30 seconds before low battery is indicated. Make sure the power is off before removing the battery pack, and recharge the battery.

	Cause	Solution
→	Battery isn't full	Recharge the batteries
→	1.Received data over the buffer quota. 2.The protocol between the printer and host doesn't match	1.Adjust the data amount at the host side so that it won't exceed the buffering quota. 2.Match the protocol
→	FLASH ROM reading/writing error	1.Replace the FLASH ROM * 2.Download the program again *
→	The head is broken	Replace the head *
→	1.Cover isn't locked 2.Cover micro switch is not working properly	1.Lock the cover 2.Adjust the micro switch *
→	Out of paper	Set new label
→	1. Sensor level isn't accurate. 2.Sensor type doesn't match. 3.Label is meandering	1.Adjust the sensor level * 2.Adjust the sensor type 3.Reset the labels properly
→	You are approaching the quota on the buffer	Pause the data transmission and wait till the buffer is empty before trying again
→	Not an error. The over heating protection function activates when the head temperature rises above 55°C.	The function will deactivate when the head temperature goes down to 50°C.

\* Consult your local dealer or Customer Service Center.

# 8. Everyday Maintenance



After pressing the power key to turn the printer off and removing the battery pack, follow the directions below.

## **Cleaning the Thermal Head**

- (1) Open the cover by sliding the cover open/close lever.
- (2) Wipe clean with cloth and alcohol.
  - \* Do not use thinners, benzene, or kerosene.

## **Cleaning the Platen/Dispense Rollers**

- (1) Open the cover by sliding the cover open/close lever.
- (2) Wipe clean with cloth and alcohol.
  - \* Do not use thinners, benzene, or kerosene.



# 9. Reference

## Options

9

### User options

#### Battery pack (one included)

To use as back up.



#### Battery charger

To recharge battery pack.



#### AC adapter for printer

Use the adapter to supply power from a household electrical outlet (AC100V). Connect the DC output jack of \* Do not use thinners, benzene, or kerosene.\* Do not use thinners, benzene, or kerosene.the adapter to the printer.



#### Caution

- Always use the specified adapter.
- Always hold the printer when pulling out or plugging in the jack.
- Be careful not to damage the cords.
- Store away unplugged if not used.

### **Shock absorbing / Splash-proof case (with shoulder belt)**

Makes carrying the printer easy.

**9**

### **RS232C cable**

Connects the printer to computers and handy terminals.

Reference

### **Interface protector**

Protects the RS-232C plug from shock and pressure when carrying.

### **Maker Options**

#### **Weak radio unit**

To use when communicating with specified handy terminal.

#### **Core-less function**

To print on label rolls without the core.

## Non-separated function

Use to print on labels without the seal.

### Printing

- (1) Follow directions on the Continuous mode from step 1 to 5 on page 23 and 24.
- (2) Follow step 1 of the directions on the Dispense mode on page 25.
- (3) Pick up the corner of the sheet and pull upward.  
The label will cut along the perforated line.

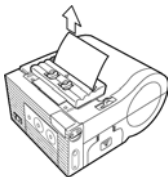

- \* Number of sheets that can be printed on this function will differ from the Continuous / Dispense mode.
- \* Should the Non-separated label tear other than at the perforated lines, and the printing is improper, perform the procedures on page 44.

**When the next printing is not performed**

- (1) Press the Print key while on-line, and turn the printer off-line
- (2) Press the Feed key and forward the sheet.
- (3) When the sheet stops, cut along the perforated line.
- (4) Press the Print key and go back to on-line status.

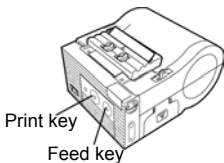

## Ordering Repairs

---

- Always attach to the printer a sample of the defective print and note the functional problem before sending it out when requesting for repairs.
- After repairs have been made, you may be asked to recover the format of the printer by yourself.

## Basic Specifications

9

Reference

Items	Details
Printing System	Thermal
Head Density	8 Heads/mm
Maximum Printing Size	Width 48mm X Pitch 156mm
Printing Speed	Max. 62.5mm/sec. (may vary from environment and printing rate)
Size and Weight	Printer : W94mm X D 120mm X H 64mm (excluding the belt clip) Weighs under 430g (with battery and without the protector)
Power (Battery)	Packet type (Lithium ion battery); 1500mAh (DC7.2V); Able to print 2 rolls of thermal labels (26m) with fully charged battery in the Continuous mode. (Printing rate under 30%)
Paper Thickness	Always use specified labels 0.08 mm – 0.18mm
Label Shape	Rolled paper
Label Size	Maximum outer diameter: 58mm Width : 25.4 – 55 mm (28.4 – 58 mm) Pitch : 13 – 160 mm (16 – 163 mm)
Printing Mode	Continuous and Dispense
Self Diagnosing Function	Head Check / Battery Check / Paper end Head Open / Test Printing
Power Save Function	Into the Sleep mode after 5 seconds without any operation, and the Auto power off mode after 5 minutes.
Interface <ul style="list-style-type: none"><li>• RS232C</li><li>• TTL</li><li>• Wireless</li><li>• Optical coupler</li></ul>	High density special connector  Weak radio unit (option) IrDA (IrDA Standard Ver.1.2 compliant, Transmittal Distance: Max. 15 – 20 cm)
Label Sensor	Opaque Projector sensor

Items	Details
Font Magnification	X 1 – 6
Character rotation	0°, 90°, 180°, 270°
Font	Sato standard font : X21, X22, X23, Kanji 16 X 16, 22 X 22, 24 X 24 Kaku Gothic (JIS First/ Second standard)
Barcode	JAN8/13, UPC-E/UPC-A, NW-7, CODE39, CODE 93, CODE128, INTERLEAVE 2 of 5, Customer Bar Code Barcodes are as follows : Parallel Barcodes: Slim line width over 2 dots Serial Barcodes : Slim line width over 3 dots
Two Dimension Code	PDF 417, QR code
Function key	Print key Feed key
Indicator	1 LED indicator (with Green, Red, Orange lighting)
Noise Gauge	Noise radiation: VCCI-A Static withstanding pressure: Level 2
Protection Function	Suspension of action upon detection of low batteries.
Impermeability	Splash proof II (JIS) compliant (with the optional Shock absorbing -splash proof case ) * Excluding when the printer is cabled.
Environment Conditions (including battery)	Operation temperature : 5 – 40°C Humidity : 25 – 80% (without condensation) Storage Temperature : –5 – 45°C Humidity : 25 – 80% (without condensation) excluding the label condition
Option	Weak radio unit, Battery charger, AC adapter (AC100V), Interface protector, Shock absorbing / splash proof case (with shoulder straps), RS-232C cable, Battery pack, the Core-less function and the Non-separated function

## After Service

---

9

To ensure that our products are used at their best, we provides repair and maintenance services to our clients.

Reference

### Services

	Replacing parts	Technical fee
Guaranteed Maintenance Period Service	No charge, in accordance with the guarantee	No charge, in accordance with the guarantee
Maintenance Contract Service	Included in the contract fee	Included in the contract fee
"Spot" service	Pay per service	Pay per service

Holding period for replacement parts is 5 years after purchase.

### Details of the Maintenance Service

Deposit	Carry-in	Should malfunction occurs, the printer should be brought (sent) to the nearest Customer Service Center or dealer. Please note we will not be liable for shipping fees.
---------	----------	--

We do not dispatch any maintenance services.



## About Guaranteed Maintenance Service

### **Guaranteed Maintenance Period Service**

We guarantee free repairs for any breakdowns that occurred while being used properly, for a period of 6 months from the date of purchase. Since the conditions of the guarantee may vary from model, check the guaranty certificate.

### **Bank Account Crediting**

For payment, we recommend the "Bank Account Crediting System".

### **Stored Data**

The data and soft wares entered in the printer may be lost during repair. We recommend making back-up prior to deposit and carry-in maintenance. Make sure to check the printer for its data after repair.

## About Maintenance Contract Service

Maintenance contract service will cover after the standard guarantee period.

### Full Maintenance Service

#### 1. Purpose

The contract will be signed between you and Sato, and the maintenance will be done according to the contract.

The contract fee will be credited to the technical fee and fees for replaced parts.

#### 2. Contract fee

The contract fee will be calculated according to using circumstances.

### Contract Period

The contract period is one year, and unless otherwise requested, may renew for 4 years. Any contracts over the period of 4 years will be calculated according to each standard.

## **About “Spot” service**

After the standard 6-month guarantee period, those without the maintenance contract service may choose the “Spot” Service. Since the Maintenance contract clients are have priority, note that repairs may take time. The maintenance fee will be billed according to the service charges after each “Spot” Service.

**AVTO**